

Control of a Chiller Plant

Introduction

This case study demonstrates the control of a three stage chiller plant that cools water in a primary loop, which feeds into a secondary loop with a heat load.

System Description

The lay-out of the system is shown in Figure 1.

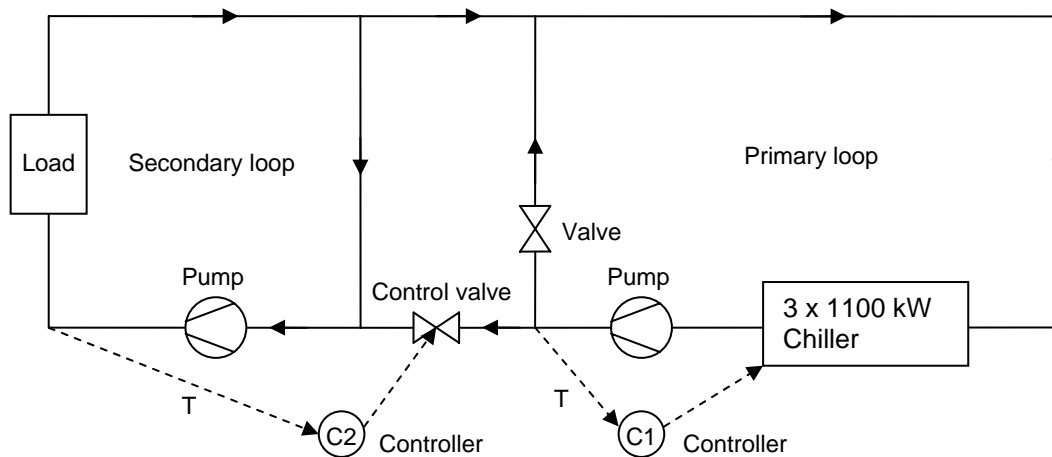

Figure 1: Layout of three-step chiller plant.

The water in the primary and secondary loops is circulated at nearly constant rates by two independent pumps. A varying heat load heats the water in the secondary loop. Controller C1 senses the temperature in the primary loop and attempts to keep the temperature constant by switching chiller stages on or off. Controller C2 senses the temperature just before the heat load and opens or closes the control valve in an attempt to keep the temperature at the inlet to the load constant.

Objective of simulation

The objective of the simulation is to investigate the operation and effectiveness of the control system in a situation where the load changes rapidly.

Flownex model

The Flownex model of the system is shown in Figure 2. The three-stage chiller is modeled by three pipes, each with a negative heat load of 1100 kW that can individually be switched on or off by separate PID controllers. The control valve is also controlled with a PID controller.

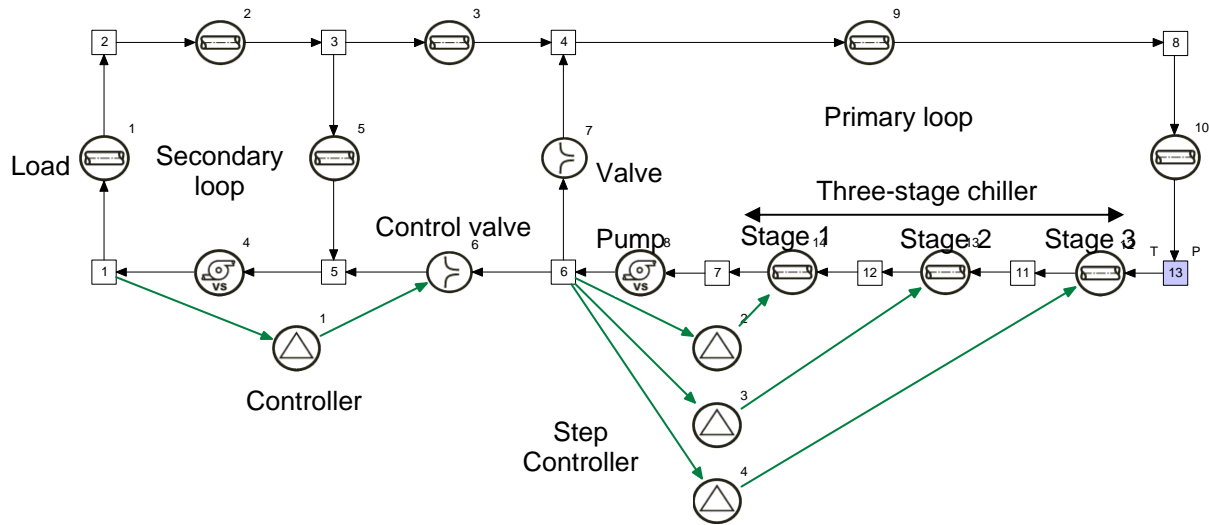

Figure 2: Flownex model of the three stage chiller plant with control system.

Description of simulation

A transient simulation is done where the load in the secondary loop is varied as shown in Figure 3.

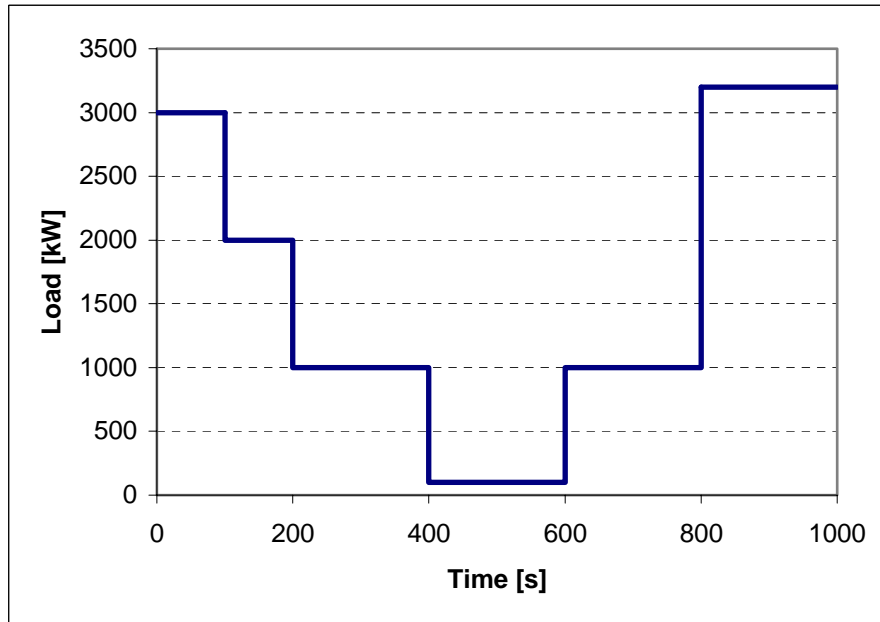

Figure 3: Variation of load with time.

The initial condition of the simulation is the steady-state solution with a fixed temperature of 45 °C at node 13.

The settings of the three step controllers for the chiller are as follows:

Stage	Setpoint	Deadband	Minimum heat	P	D
1	5 °C	1 °C	-1.1 MW	10 MW/°C	0
2	6 °C	1 °C	-1.1 MW	10 MW/°C	0
3	7 °C	1 °C	-1.1 MW	10 MW/°C	0

Figure 4 shows how the different stages will be switched on and off on rising and decreasing temperatures.

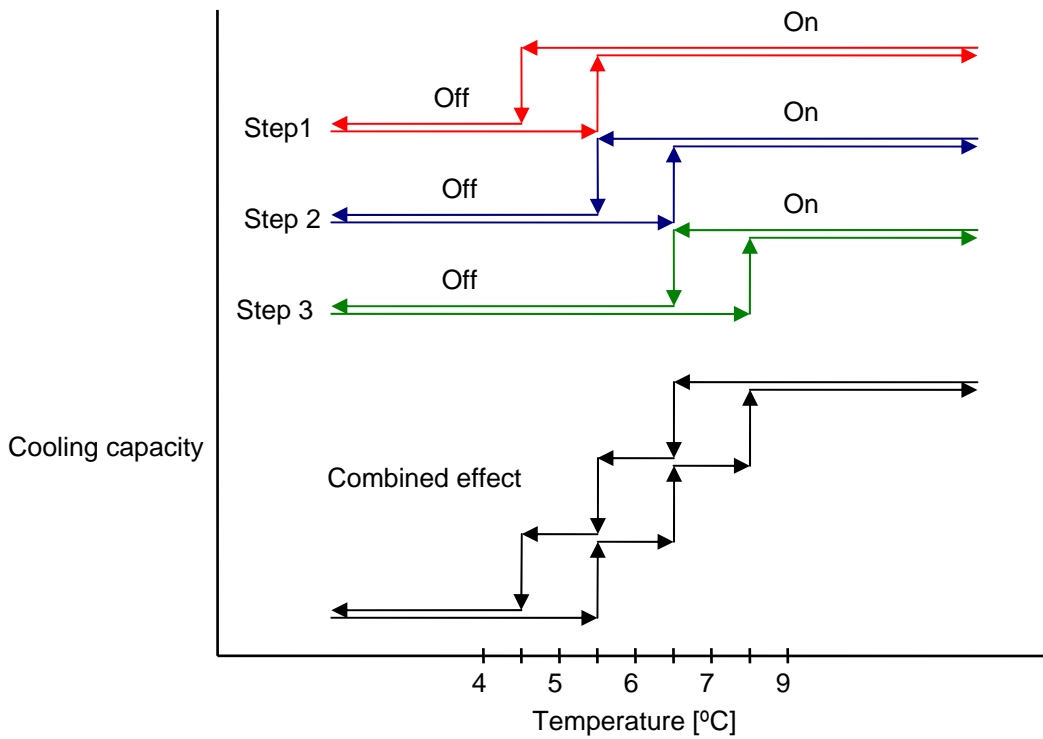

Figure 4: Settings of step controller.

Results

Figure 5 shows the variation of temperature at the inlet to the load for the case where the chiller step controller is on while the control valve controller is switched off.

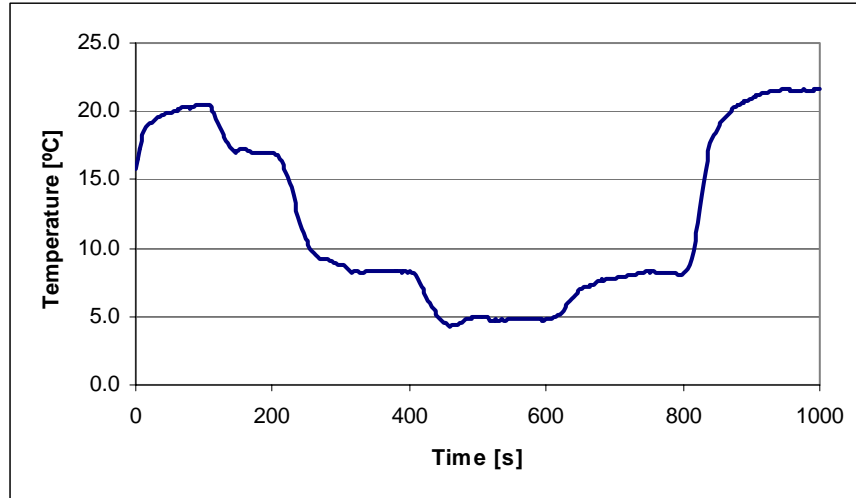

Figure 5: Temperature at inlet to the load with the control valve controller switched off.

Figure 6 shows the variation of temperature at the inlet to the load with both controllers switched on. Apart from the initial transient the control valve controller succeeds in keeping the temperature at the inlet of the load within a narrow range.

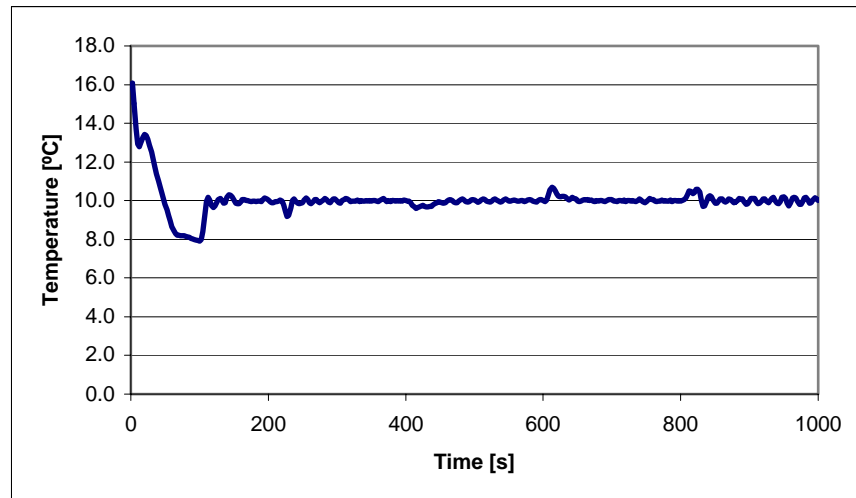

Figure 6: Temperature at inlet to the load with the control valve controller switched on.

Figure 7 shows the variation of control valve diameter with time.

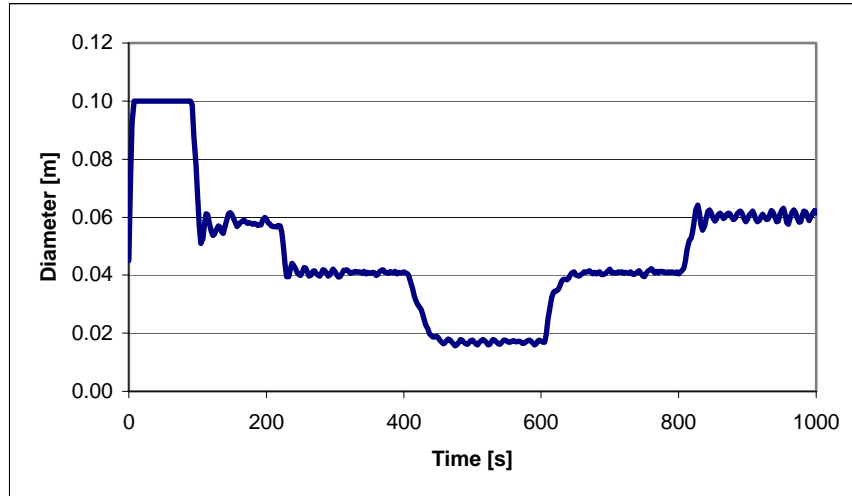

Figure 7: Variation in valve diameter with time.

Conclusion

Flownex was used to simulate the control of a three stage chiller plant using a step controller in conjunction with a controller on a bleed valve that allows colder water from the primary circuit into the warmer secondary circuit. The simulation shows that the control strategy is effective.