

# Balancing of Air Conditioning Distribution System

## Introduction

This case study demonstrates the capability of Flownex to balance air distribution systems by determining the orifice sizes or damper opening to ensure required flow at certain points in the system. In particular, this example demonstrates the balancing of a central air conditioning distribution system. All the rooms that need to be supplied are similar and a mass flow of 0.02 kg/s are required in each.

## System Description

The configuration considered in this example is shown in Figure 1. The inlet pressure and required mass flow at each outlet is known.

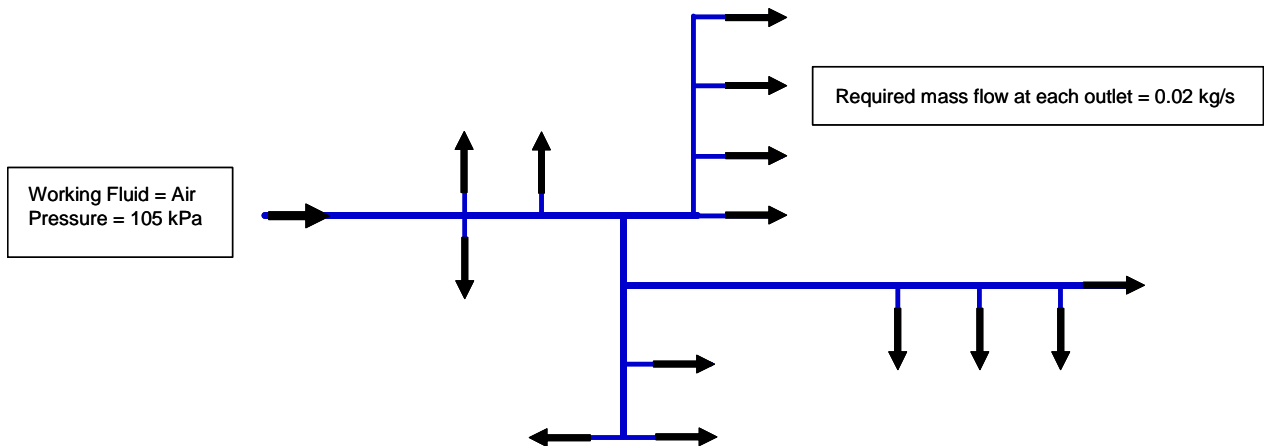

Figure 1: Schematic layout of a central air conditioning distribution system.

## Objective of simulation

The objective of the simulation is to determine the orifice ratio or damper opening in each outlet pipe to obtain balanced flow given appropriate input data for all the components as well as boundary conditions. This example illustrates the capability of Flownex to easily simulate such problems through the use of its built in orifice sizing functionality and the orifice model incorporated with the Pipe element.

## Flownex model

The Flownex model of the system is shown in Figure 2. The distribution ducts are modeled in Flownex using the Pipe element. A fixed mass flow of 0.02 kg/s is specified on each outlet Pipe element as specified in the problem statement. The inlet boundary pressure is specified on the inlet node (Node 1). The geometry and loss factors for each pipe are specified on the relevant Pipe element.

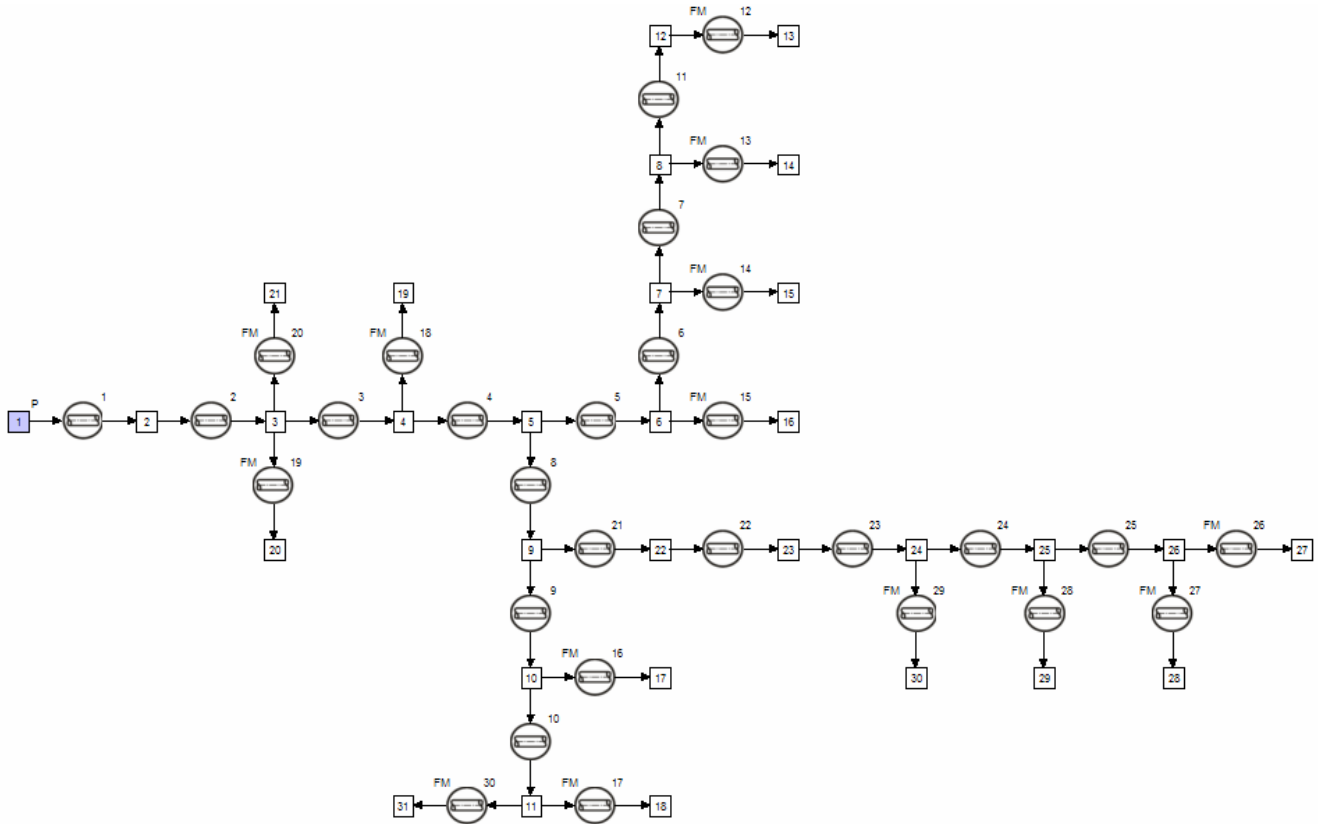

**Figure 2:** Flownex network.

**Description of simulation**

Flownex has a built in orifice sizing capability specifically designed to assist in modeling flow balancing problems. The user can specify that the orifice ratios are calculated for all Pipe elements for which a fixed mass flow was specified to obtain the specified mass flow. For this example, a reference pressure (atmospheric pressure) was specified to use as the outlet pressure for all outlet ducts.

**Results**

Table 1 gives the required orifice ratios for each parallel pipe determined by Flownex. The pipe numbers coincide with the numbers given in Figure 2.

**Table 1:** Orifice ratios determined by the Flownex

Pipe number	Orifice Diameter
12	0.021082
13	0.021081
14	0.021079
15	0.021076
16	0.021076
17	0.021078

18	0.021078
19	0.021064
20	0.021064
26	0.021091
27	0.021091
28	0.021090
29	0.021087
30	0.021078

## Conclusion

The capability of Flownex to easily simulate flow balancing problems was demonstrated in this example. The orifice ratios were determined that would give specific flow rates at each outlet of a central air conditioning distribution system. Flownex has a built in functionality that assists in solving orifice ratios for Pipe elements for which fixed mass flows are specified.